

Model **AF** mass flow meters and controllers are designed to indicate flow rates and control set flow rates of gases.

Each of these units incorporates an advanced straight tube sensor in conjunction with flow passage elements constructed of stainless steel.

LED readouts of command modules are supplied with 0 to 100 percent calibrations. Zero and span adjustments are conveniently accessible from outside of the transmitters.

Design Features

- Rigid metallic construction.
- Maximum pressure of 1000 psig (70 bars).
- 0-5 Vdc or 4-20mA signals.
- Leak integrity 1×10^{-9} smL/sec of helium.
- Accuracy of $\pm 1\%$ F.S.
- Totalizer option.
- Circuit protection.

Principles of Operation

Metered gases are divided into two laminar flow paths - one through the primary flow conduit and the other through a capillary sensor tube.

Both flow conduits are designed to ensure laminar flows and therefore the ratio of their flow rates is constant.

Two precision temperature sensing windings on the sensor tube are heated, and when flow takes place, gas carries heat from the upstream to the downstream windings. The resultant temperature differential is proportional to the change in resistance of the sensor windings.

A Wheatstone bridge design is used to monitor the temperature dependent resistance gradient on the sensor windings which is linearly proportional to the instantaneous rate of flow.

Output signals of 0 to 5Vdc or 4 to 20mA are generated indicating mass molecular based flow rates of the metered gas.

SDPROC and AFC Analog Mass Flow Controller



In AFC mass flow controllers the combined gas streams flow through a proportionating electromagnetic valve with an appropriately selected orifice. The closed loop control circuit continuously monitors the mass flow output and maintains it at the set flow rate.

Flow rates are unaffected by temperature and pressure variations within stated limitations.

Transducer power supply ports are fuse and polarity protected.

AFC mass flow controllers include an electromagnetic control valve that allows the flow to be set to any desired

flow rate within the range of the particular model. The valve is normally closed as a safety feature to ensure that gas flow is shut off in case of a power outage.

AF mass flow meters and controllers are designed to meter and control flow rates of gases.

AF mass flow meters and controllers are available with flow ranges from 10 mL/min to 100LPM [N₂]. Gases are connected by means of 1/4", 3/8", or optional 1/8" compression fittings.

These controllers may be used as bench top units or mounted by means of screws in the base.

TABLE 26 - SPECIFICATIONS

ACCURACY:	±1% of FS at calibration temperature and pressure.
CALIBRATIONS:	Performed at standard conditions [14.7 psia (101.4 kPa) and 70 °F (21.1°C)] unless otherwise stated.
REPEATABILITY:	±0.25% of full scale.
TIME CONSTANT:	AFM SERIES - 300 ms. AFC26: (Q _{max} = 10 L/min): 300 ms. AFC36: (Q _{max} = 50 L/min): 600 ms. AFC46: (Q _{max} = 100 L/min): 600 ms.
RESPONSE TIME:	AFM SERIES: Approximately 1 second to within ±2% of set flow rate for 25% to 100% of full scale flow. AFC26: (Q _{max} = 10 L/min): Approximately 1 second to within ±2% of set flow rate for 25% to 100% of full scale flow. AFC36: (Q _{max} = 50 L/min) and AFC46: (Q _{max} =100 L/min): Approximately 2 second to within ±2% of set flow rate for 25% to 100% of full scale flow.
TEMPERATURE COEFFICIENT:	0.1% of full scale/ °C.
PRESSURE COEFFICIENT:	0.01% of full scale/psi (0.07 bar).
OPTIMUM GAS PRESSURE:	25 psig (1.73 bars).
MAXIMUM GAS PRESSURE:	1000 psig (70 bars) maximum. Standard calibration is at 20 psig (1.4 bars) inlet pressure.
MAX. PRESSURE DROP: (at full scale flow)	Refer to Table 29.
GAS AND AMBIENT TEMPERATURE:	32 °F to 122 °F (0 °C to 50 °C). 14 °F to 122 °F (-10 °C to 50 °C) - Dry gases only.
LEAK INTEGRITY:	1 x 10 ⁻⁹ smL/sec of helium maximum, to the outside environment.
**MATERIALS IN FLUID CONTACT:	316 stainless steel, 416 stainless steel, Viton® O-rings. Optional O-rings: Buna®, EPR and Kalrez®.
ATTITUDE SENSITIVITY:	No greater than ±15 degree rotation from horizontal to vertical; standard calibration is in horizontal position.
OUTPUT SIGNALS:	Linear 0-5 Vdc (2000 W min. load impedance); 4 - 20 mA optional (0 - 500 Ω loop resistance); maximum noise 20 mV peak to peak.
CONNECTIONS:	AFM /AFC26, AFM /AFC36: 1/4" compression fittings. Optional: 6mm compression or 3/8" compression or 1/4" VCR® or 1/8" compression fittings (AFM/AFC26). AFM/AFC 46: 3/8" compression fittings.
TRANSDUCER INPUT POWER:	AFM/AFC 26: +15 ±5% Vdc, 80 mA max, 1.2W; -15 ± 5% Vdc, 200 mA max, 3W; AFC 36 /AFC 46: +15 ±5% Vdc, 220 mA max, 3.3W; -15 ±5% Vdc, 600 mA max, 9W.
CIRCUIT PROTECTION:	Circuit boards have built-in polarity reversal protection. Replaceable fuses provide power input protection.

***The selection of materials of construction, is the responsibility of the customer. The company accepts no liability.*

Leak Integrity

1 x 10⁻⁹ smL/sec of helium max to outside environment.

Mass Flow Systems

Complete Mass Flow Systems include Command Modules, transducers and cables. Command modules contain appropriate power supplies, 24x2 alpha-numeric dot matrix display read-out, and four panel buttons which provide complete control over all the various functions necessary to measure and/or control flow.

Optional built in Ethernet interface allows accessing any Internet-connected SDPROC from a browser on your work station, PC, or laptop computer.

TABLE 27 - FLOW RANGES FOR AFC / AFM

AFC 26 / AFM 26	
CODE	UNITS [NITROGEN]
01	0 to 10 mL/min
02	0 to 20 mL/min
03	0 to 50 mL/min
04	0 to 100 mL/min
05	0 to 200 mL/min
06	0 to 500 mL/min
07	0 to 1 L/min
08	0 to 2 L/min
09	0 to 5 L/min
10	0 to 10 L/min
AFC 36 / AFM36	
11	0 to 15 L/min
30	0 to 20 L/min
31	0 to 30 L/min
32	0 to 40 L/min
33	0 to 50 L/min
AFC 46 / AFM46	
40	0 to 60 L/min
41	0 to 80 L/min
42	0 to 100 L/min

TABLE 28 - MAXIMUM PRESSURE DROP FOR AFC / AFM

FLOW RATE [liters/min]	AFC SERIES		AFM SERIES	
	[psid]	[bars]	[psid]	[bars]
up to 10	1.06	0.072	0.04	0.003
up to 15	3.87	0.26	0.09	0.006
up to 20	2.0	0.136	0.44	0.030
up to 30	3.5	0.238	1.18	0.080
up to 40	5.5	0.374	2.18	0.148
up to 50	8	0.544	3.23	0.220
up to 100	18.9	1.302	8.08	0.557



AFC Analog Mass Flow Controller



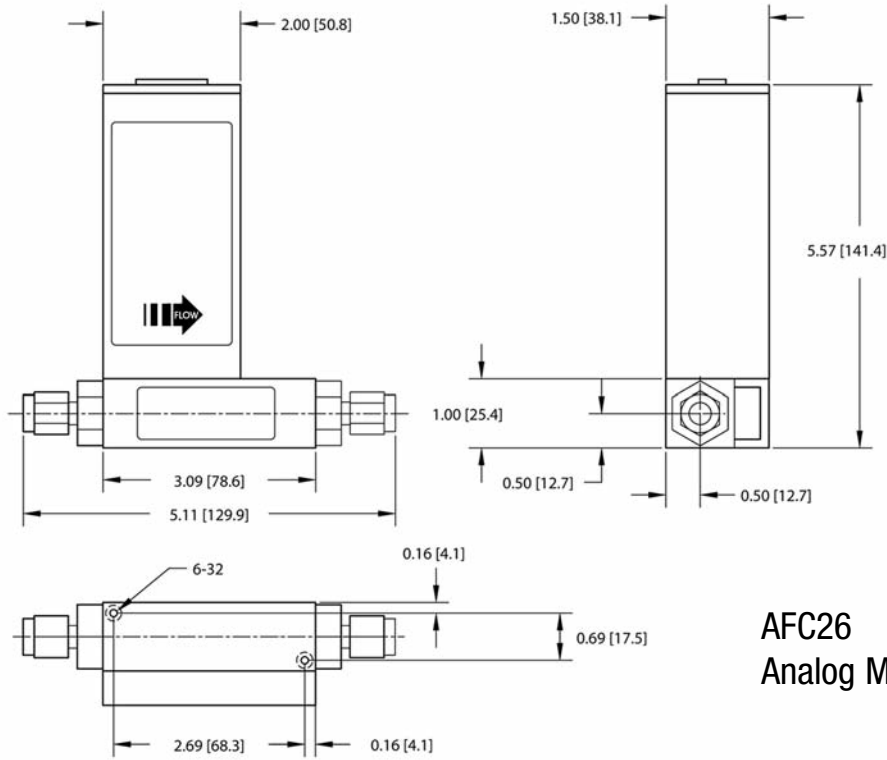

AFC26
Analog Mass Flow Controller

DIMENSIONS: INCH [mm]

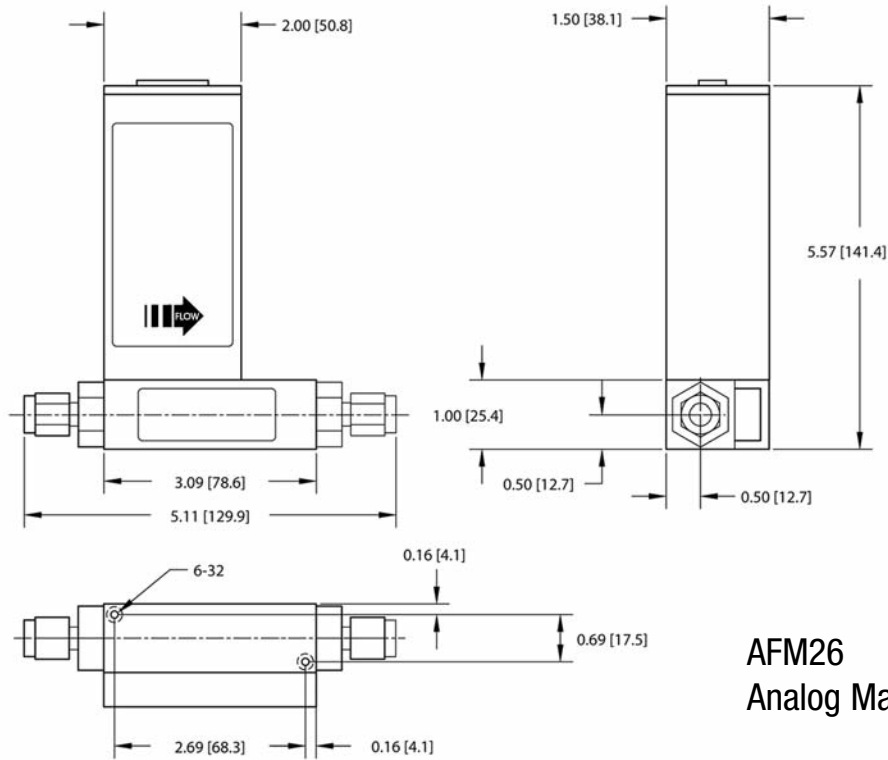

AFM26
Analog Mass Flow Meter

DIMENSIONS: INCH [mm]

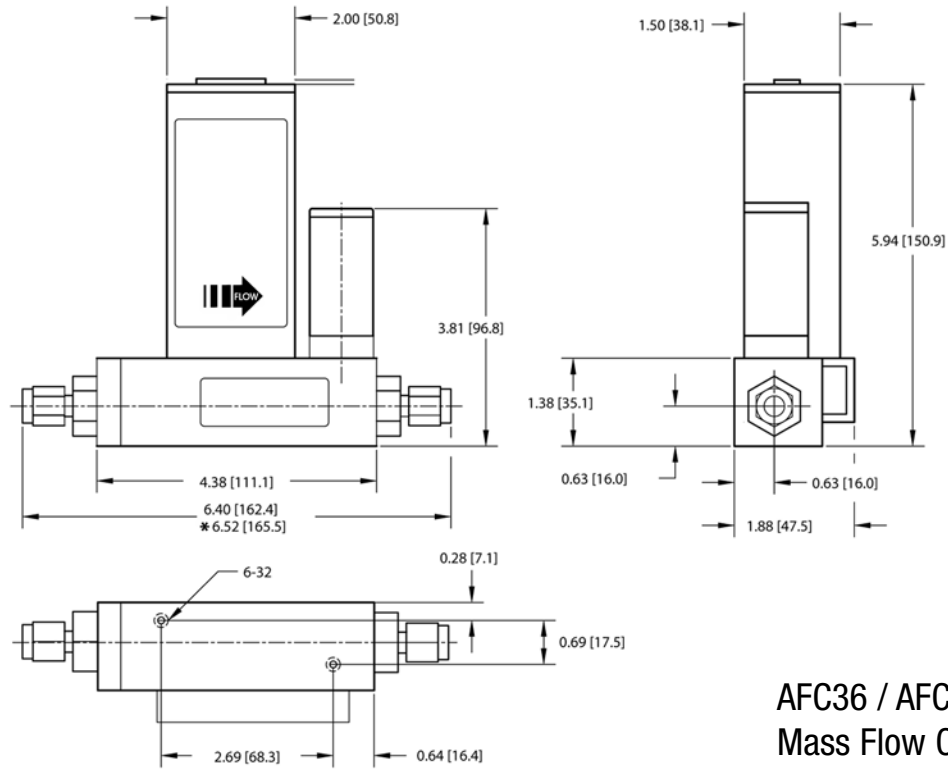

**AFC36 / AFC46
Mass Flow Controller**

DIMENSIONS: INCH [mm] * FOR HIGH FLOW MASS FLOW CONTROLLER ONLY

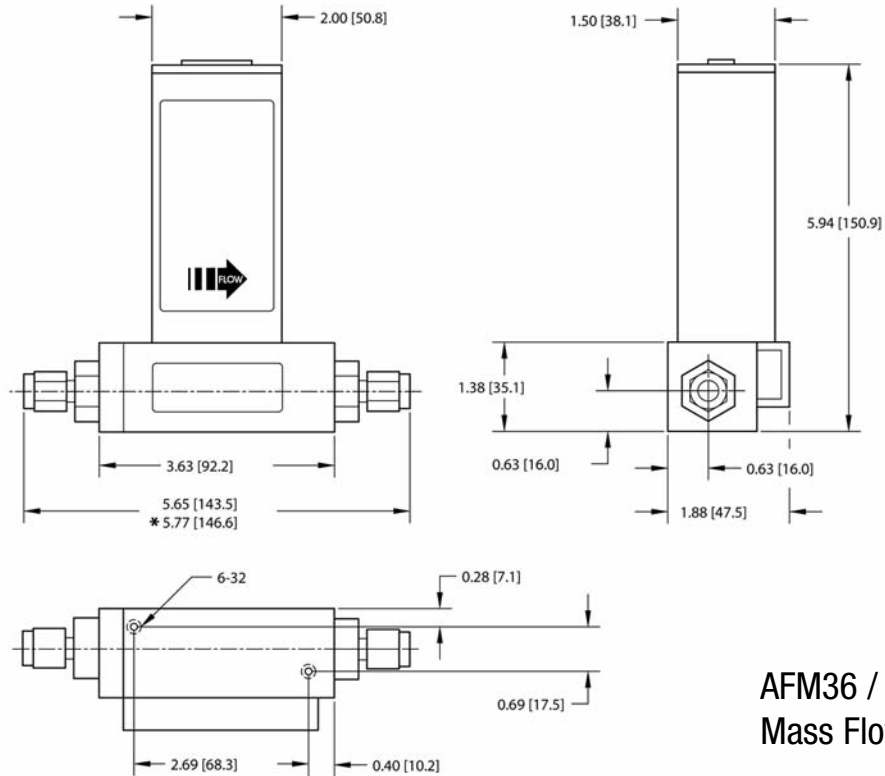

**AFM36 / AFM46
Mass Flow Meter**

DIMENSIONS: INCH [mm] * FOR HIGH FLOW MASS FLOWMETER ONLY

MODEL		
AFC		
AFM		
SERIES	MAX. FLOW (N ₂)	
26	10 L/min	
36	50 L/min	
46	100 L/min	
MATERIAL		
S	Stainless Steel	
SEALS		
V	Viton®	
B	Buna®	
E	EPR	
T	PTFE / Kalrez®	
FITTINGS	MODEL	
A	1/4" Compression	AFM/AFC 26, 36
B	1/8" Compression	AFM/AFC 26, 36
C	1/4" VCR®	AFM/AFC 26, 36
D	3/8" Compression	AFM/AFC 26, 36, 46
H	6mm Compression	AFM/AFC 26, 36
CONNECTOR		
D	D Connector	
DISPLAY		
N	No Display	
POWER		
5	±15 Vdc	
INPUT / OUTPUT SIGNAL AFM ONLY		
A	*n.a. / 0-5 Vdc	
B	*n.a. / 4-20mA	
INPUT / OUTPUT SIGNAL AFC ONLY		
C	0-5Vdc / 0-5Vdc	
D	0-5Vdc / 4-20mA	
DIGITAL INTERFACE		
0	NONE	

AFM	36	S	—	V	A	D	N	5	—	A	0
-----	----	---	---	---	---	---	---	---	---	---	---

EXAMPLE: DFM36S-VADN5-A0 50 L/min [N₂] 20 psig
SPECIFY: GAS, FLOW RANGE and PRESSURE.

AFM36 stainless steel, Viton® seals with 1/4" compression fittings, D connector, Without a display, ±15 Vdc, *n.a./0-5Vdc input/output signal, and no digital interface.